

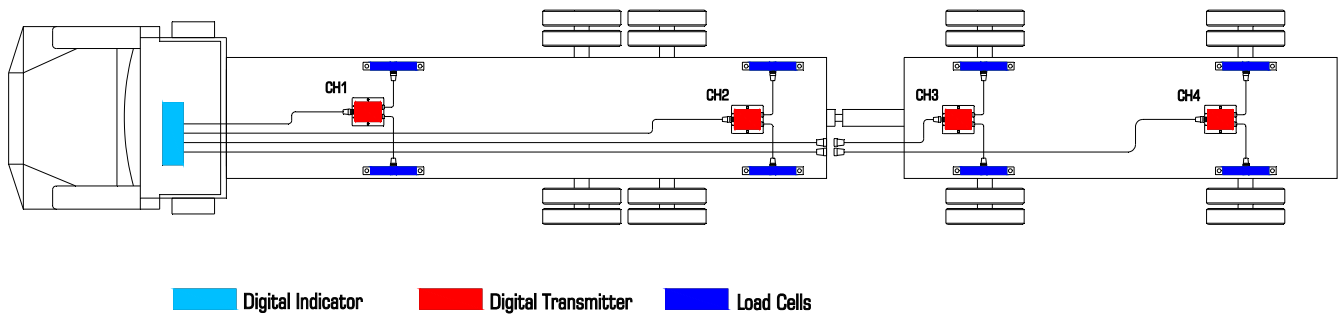

Short Logger System

The logging systems include the innovative PNT 9704 Weigh indicators, the first truly self-diagnostic indicators with on-screen programming. The load cells are machined from high-alloy steel, heat treated for maximum strength, and then tested to a 300 percent overload capacity. The sensing elements in the double-gaged steel shear-beam load cells feature full-twist compensation and are fully encapsulated to withstand the harshest environmental conditions. Accuracy 1% of net payload and easy to operate.



9704 Digital Indicator



7042 Digital Transmitter



532623 Load Cell

Short Logger Full System #79704

- (1) 9704 Indicator (4-Channel)
- (4) 7042 Transcoders
- (2) 216-35 35 ft Truck cable
- (2) 216-80 80 ft Trailer cable
- (1) 218-15 15 ft Power cable
- (8) 532623 26" Accu-Beam Load Cells
- (8) 2050 26" Load Cell Mounting Kits

